

PRISM MEDICAL UK



FREEWAY

Ceiling Track Hoists

Architects Pack



Moving and Handling Solutions

PRISM MEDICAL UK



HEALTHCARE DIVISION

PRISM MEDICAL UK



Prism Medical UK has over 20 years experience in developing and supplying moving, handling and bathing equipment

Our mission is to save the healthcare system money and improve the quality of life of the mobility disadvantaged and their caregivers by providing superior services and products that most effectively solve the problems related to moving and handling people.

PRISM MEDICAL UK



HEALTHCARE DIVISION

The Healthcare Division has been established to meet the specific moving, handling and bathing requirements of acute hospitals and special schools .

The Healthcare Division are able to offer an extensive range of ceiling track hoists, aluminium mobile lifters and assisted bathing equipment all designed for heavy repetitive usage in hospitals and special schools with a comprehensive range of slings and accessories backed up by a large dedicated team of installers and preventative maintenance engineers across the UK.



HOIST PRODUCT RANGE

Prism Medical provides safe, reliable and effective hoisting solutions for carers and patients who can no longer safely manage a manually assisted transfer.

A wide range of hoisting systems are available to suit many different environments and situations; from mobile floor hoists, floor mounted gantry hoist systems through to fixed installation ceiling track hoist systems.

A ceiling track hoist enables a carer to hoist and transfer a patient from one location to another. It is simple, unrestricted, friendly, and easy to use. The hoist runs on a static ceiling track which is customised to your requirements, designed and installed by the Prism Medical Survey and Installation department. All Prism Medical Ceiling Track hoists are manufactured to BS EN10535 2006 standards.

The hoist is powered by an on board battery pack and is charged at an in-line charger mounted neatly within the end of the track. A major benefit to implementing a ceiling track hoist is that because it is at ceiling level, it is unobtrusive and does not require storage, making it ideal for areas with limited space.

Freeway P-200 Portable Hoist



Freeway Transactive Hoist



Freeway TransactiveXtra



What, Where & How

Things to consider when specifying a ceiling track hoist.

1. What is the weight of the client or potential user group? What hoists are available?
2. To which locations does the hoist need to reach?
3. How will the hoist be installed?

1. What is the weight of the client or potential user group? What hoists are available?

Prism Medical supplies a wide range of hoists to suit all client groups. The Transactive hoists are available in both Power Traverse and Manual Traverse versions. Prism Medical also supply the Transportable hoist that has an impressive max load of 200Kg. This hoist can be taken from room to room and used on numerous tracks and is manual traverse only.

Hoist Model			
P-200	Transactive	TransactiveXtra	Max Load
	F130 P/M-(Power or Manual)	TA XTRA 130 P/M-(Power or Manual)	130 Kgs
	F160P/M-(Power or Manual)	TA XTRA 160 P/M-(Power or Manual)	160 Kgs
	F200P/M-(Power or Manual)	TA XTRA 200 P/M-(Power or Manual)	200 Kgs
		TA XTRA 270 Power Trav	270 Kgs
	F300P/M-(Power or Manual)		300Kgs
P-200			200Kgs

2. To which locations does the hoist need to reach?

Prism Medical's surveyors can design a track system to satisfy the needs of the client(s). System designs range from simple straight tracks that will transfer from a bed to chair to more complex arrangements that can service baths, changing areas, wc's, hospital wards, mortuaries, room to room systems and swimming pools.

3. How will the hoist be installed?

Prism Medical have a wide range of installation methods that enable the ceiling hoist to be installed to any suitable ceiling. If the ceiling is found to be not capable of any additional loading, then a bespoke gantry system can be designed to suit the property. See installation methods section.

Typical example of the Sequence for an installation of a Hoist in a Hospital

The sequence below details a typical installation sequence once an architect has been commissioned to produce drawings to a specification. The sequence comprises of five phases:

1. Initial Designs 2. Detailed Specifications 3. First fix 4. Second Fix 5. Training

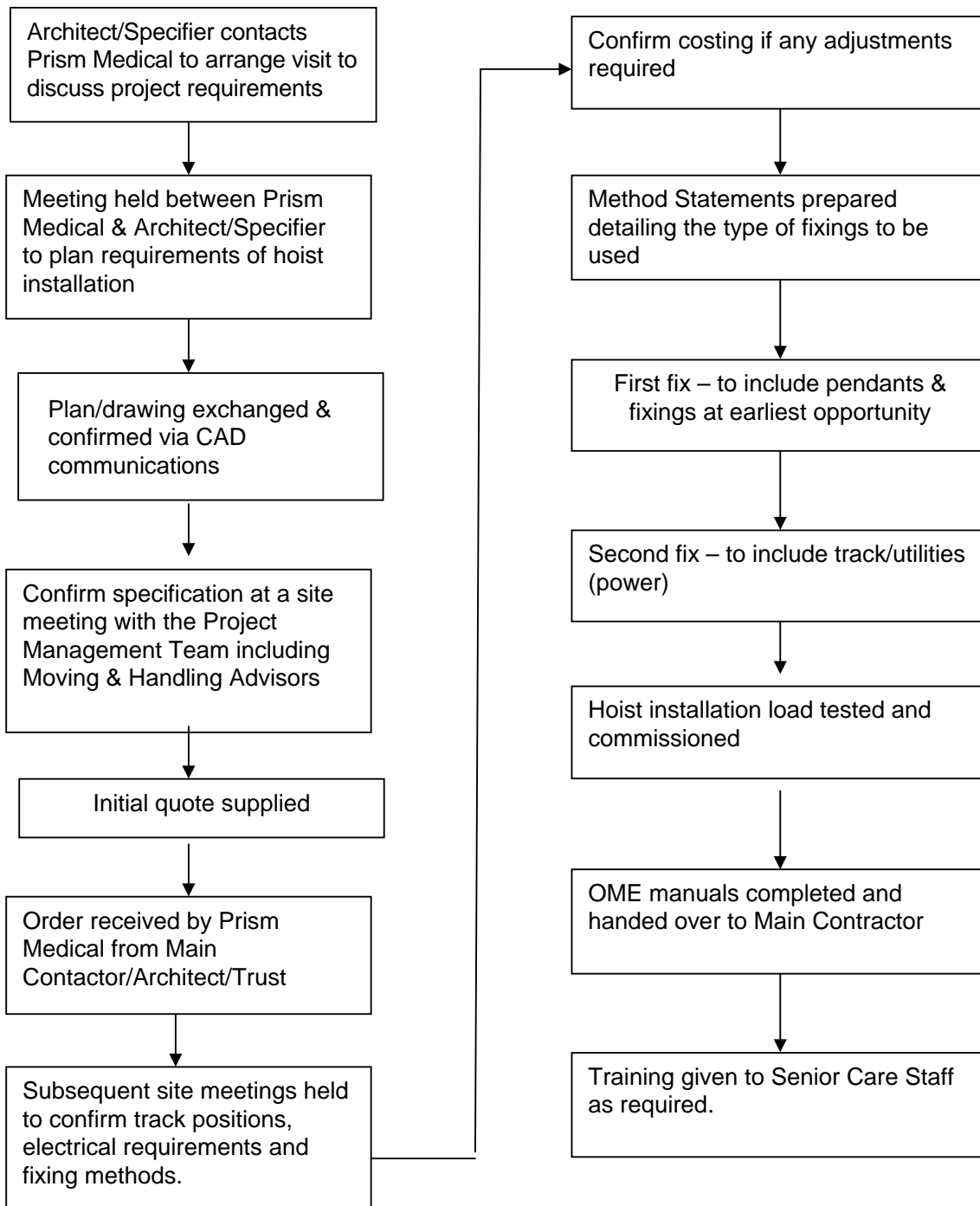

HOIST SPECIFICATIONS

Transactive 130, 160, 200 & 300Kg - Hoist Dimensions

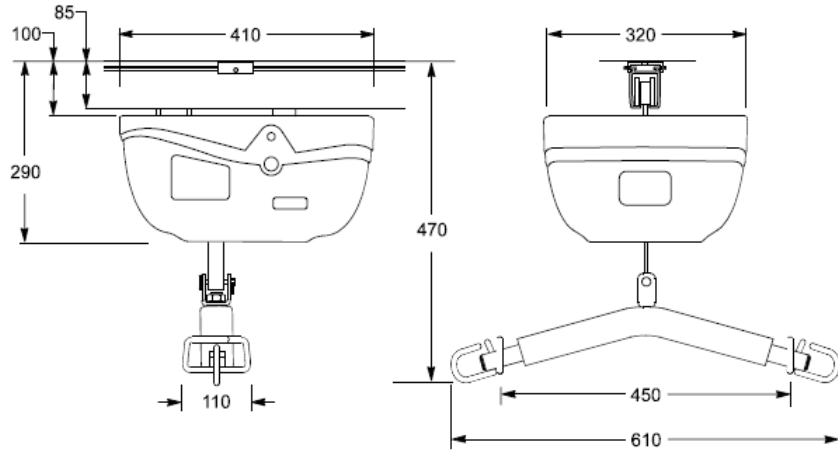

Transactive Xtra 130, 160, 200 & 270Kg - Hoist Dimensions

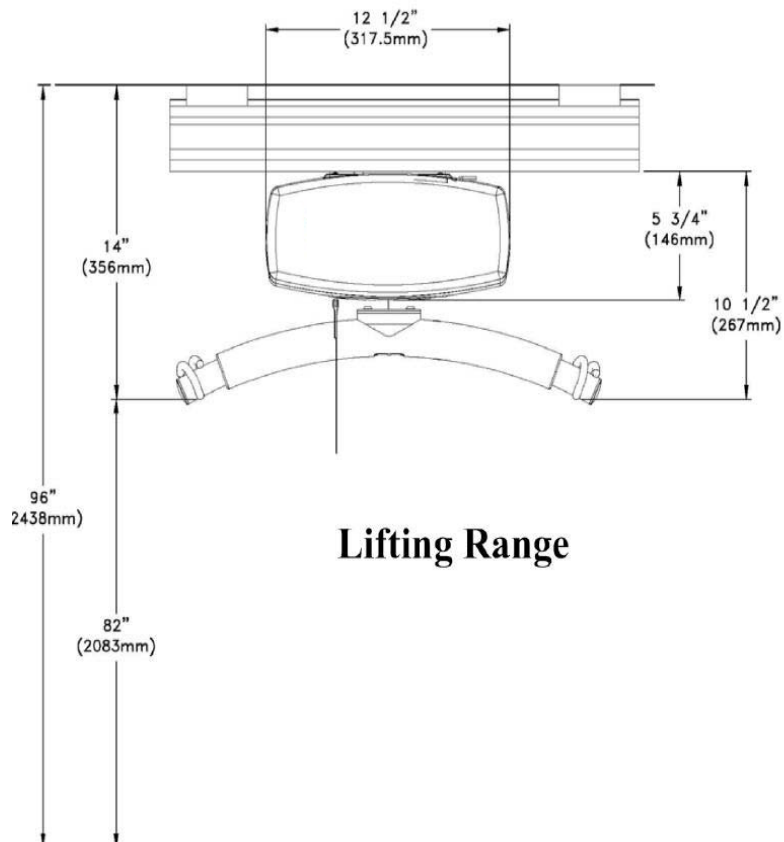

P-200 - Hoist Dimensions

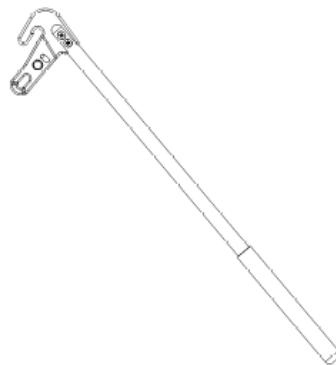
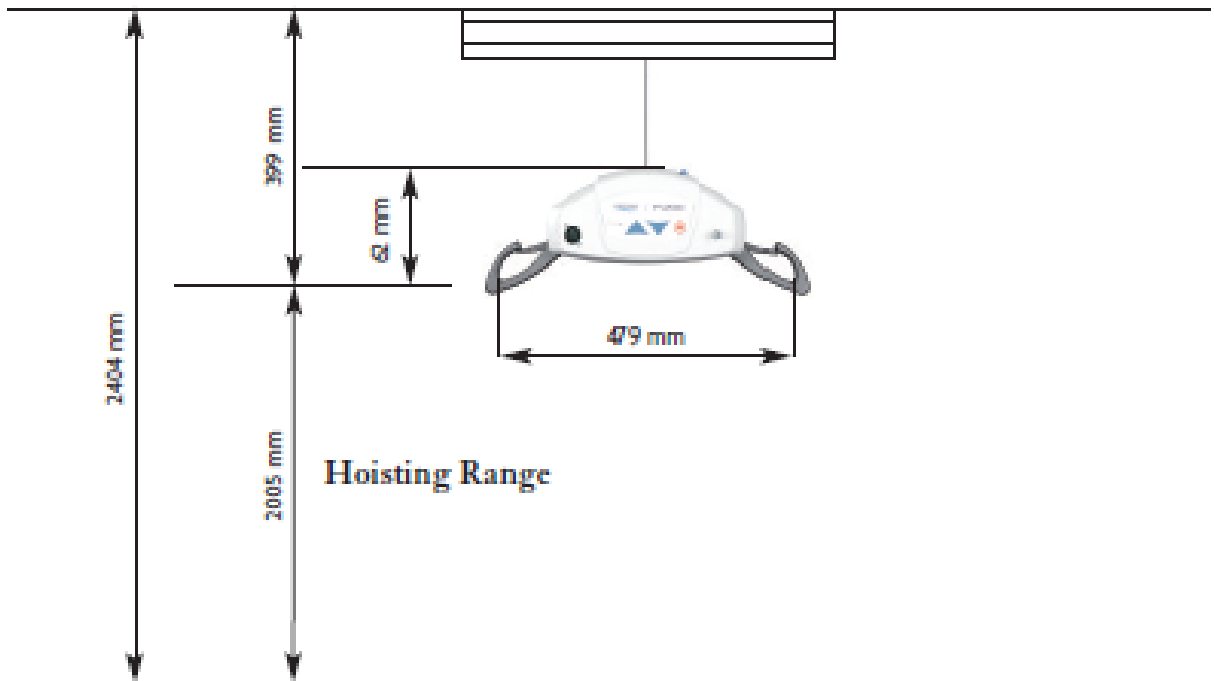

Optional Aluminium Reacher - Can be used to aid attaching the P-200 to the gantry/track system

TRACK TYPES, WEIGHTS & CONSTRUCTION

Single Track is available in the following standard lengths:-

- 2.5m
- 3.0m
- 5.0m

Double / Piggy Back Track is available only in:-

- 5.0m Length

Track construction – Extruded Aluminium track coated white.

All tracking is either re-usable or can be recycled in an environmentally friendly manner.

Single Track weight - 2.5 metre length - 6.4kg

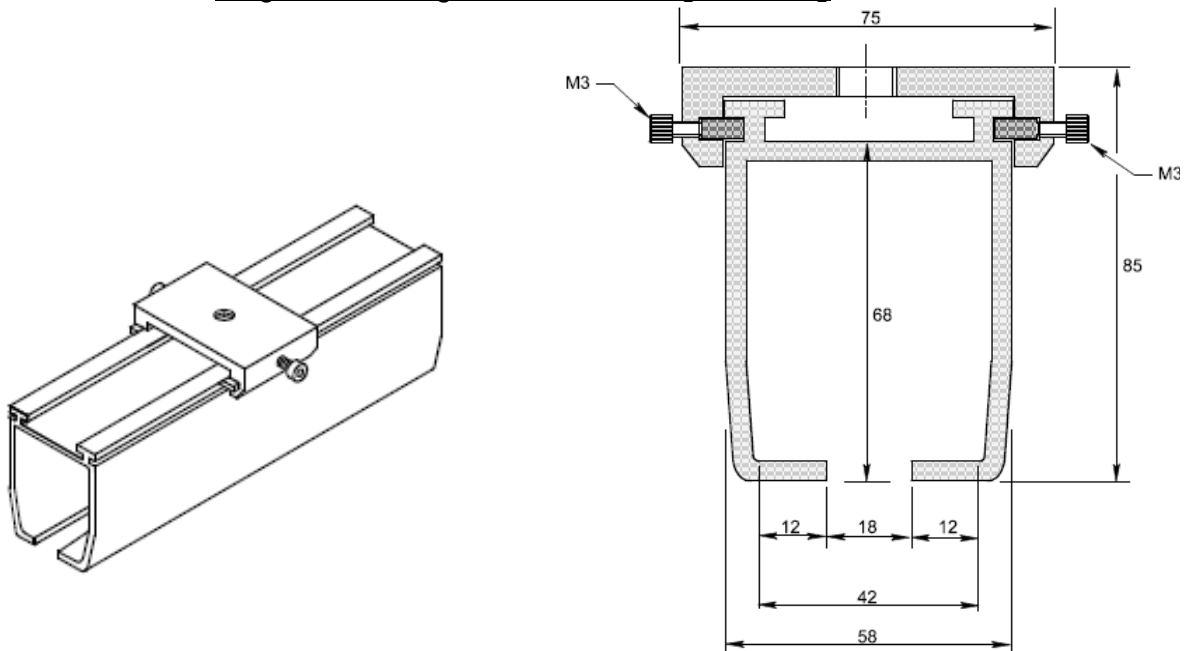

Piggy back for tracking - 5 metre length – 17.5kg

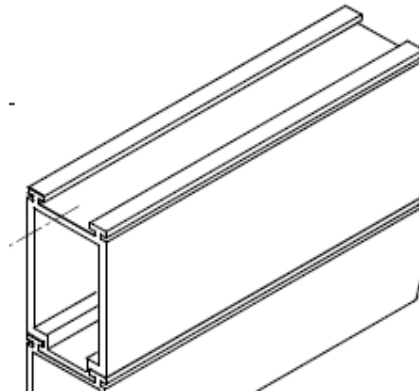

Combined weight of 5m Single + Double Track = 30.3kg

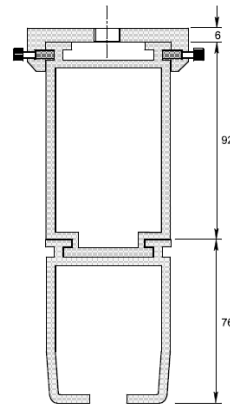
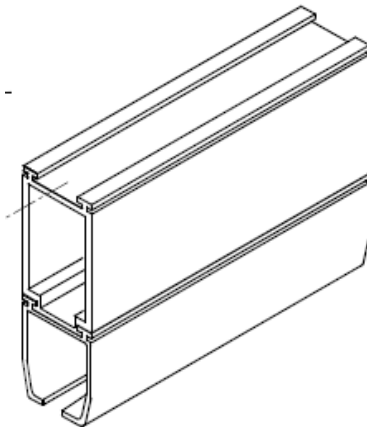

Track Fixing Brackets

55mm Standard Track Brackets

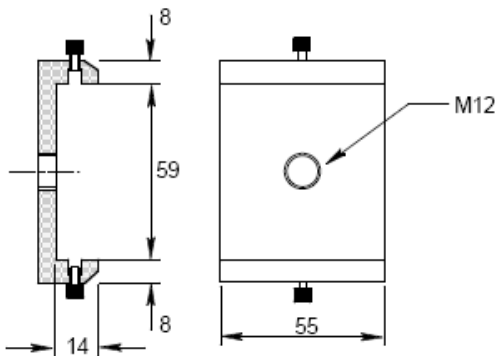

110mm Double / Jointer Brackets

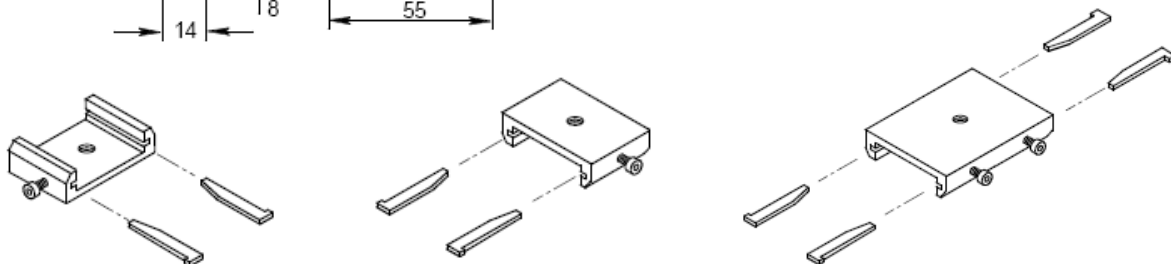
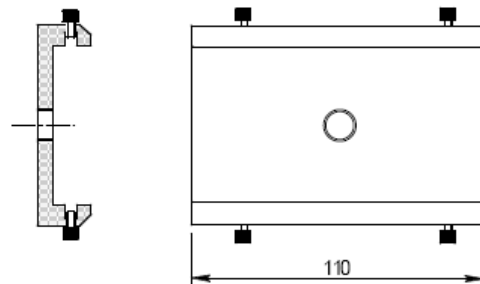

Track Bend Options

Bends are available in the following options:-

- 15 degree bend
- 22.5 degree bend
- 45 degree bend
- 90 degree bend

Each bend has a 650mm straight section at each side of the central curved area.

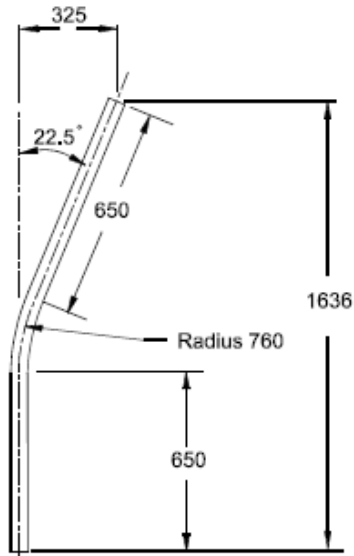

22.5° Bend Track – standard part dimensions

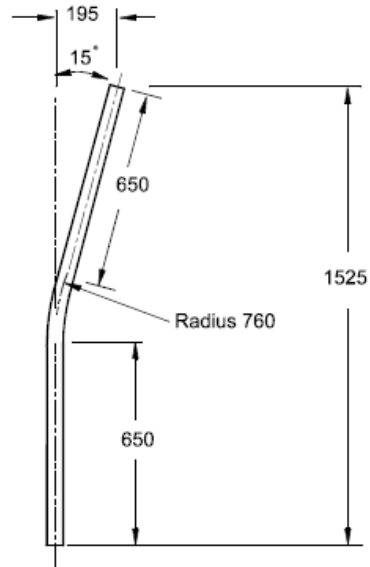

15° Bend Track – standard part dimensions

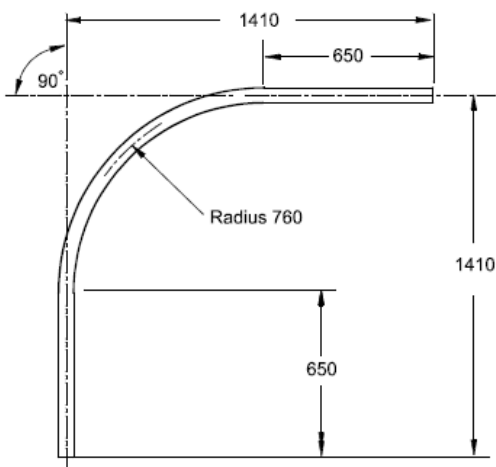

90° Bend Track – standard part dimensions

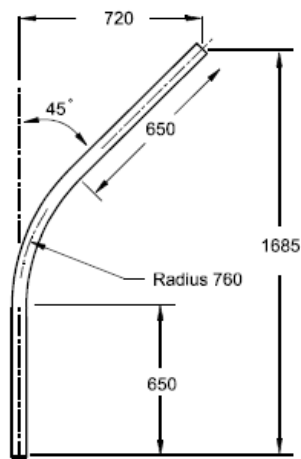

45° Bend Track – standard part dimensions

Installation Methods

TYPES OF INSTALLATION

The main fixing methods of suspending the track are:

1. Coachscrew
2. Spanning Ceiling Joists
3. Joist Hanger
4. Fixing to Concrete
5. Wall to Wall
6. Steelwork & Gantry Leg Systems

COACH-SCREW METHOD OF FIXING

Using coach-screws is the quickest and easiest way of installing a track system. It has the advantage that on a new build scheme, the joists can be positioned in specified locations to enable minimum disruption when the hoist is installed. It is very important to establish the direction, depth, distance apart and width of the joists before fitting the brackets. The joists should have a minimum depth of 125mm and a minimum width of 50mm. The track should never be fastened along the length of a single timber that is less than 75mm wide. The track should be fitted across the joists and attached to every other joist (max 800mm spacing) using M10 x 100mm Coach-screws. Coach screws should never be used on Pre-stressed trusses.

Track running at a tangent to the ceiling joists

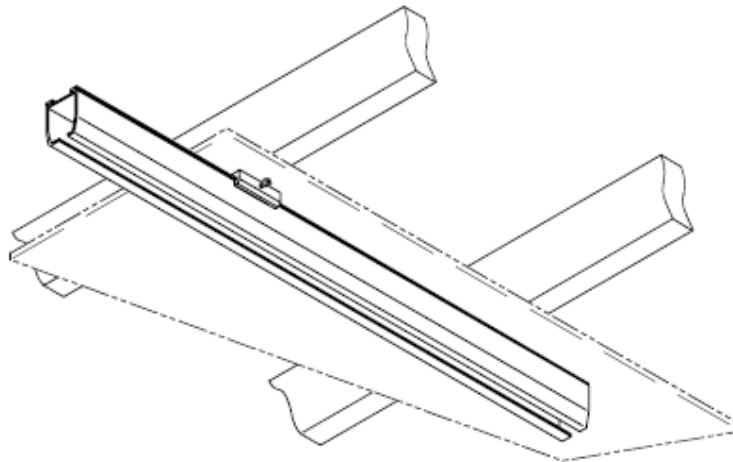

Track Coachscrewed direct to joists

Track running the same direction as the ceiling joists

When the track is running the same direction as the joists, it is necessary to use flat bar coachscrew support plates as shown below. Tracks should not be fitted to a single joist which is less than 75mm wide. If a builder has fitted a single timber for the hoist to be coachscrewed to, it is important to ensure that it is a single timber and not two that have been bolted together.

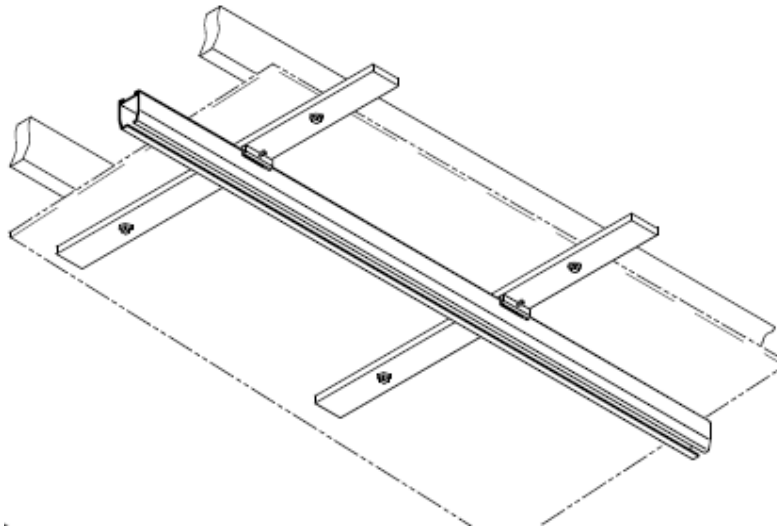

Coachscrew support plates

SPANNING CEILING JOISTS – Steel channel Method of fixing

To span the joists with steel channel, you must firstly be able to access the roof space above the room where the hoist is to be sited and secondly the ceiling must be of sound construction to withstand the required load test. It would be advisable to contact Prism Medical to discuss point loads prior to specifying timber sizes on new installations.

This method of installation can be used irrespective of the joist direction.

To follow are various drawings showing this method of fixing:-

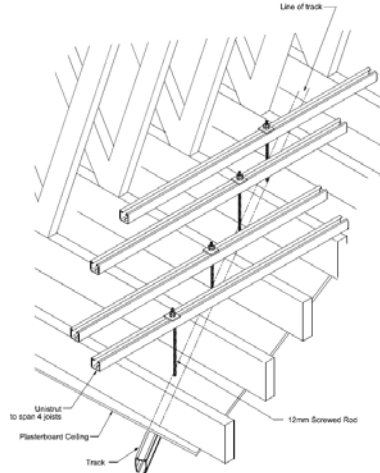

Isometric drawing of the steel channel spanning the joists

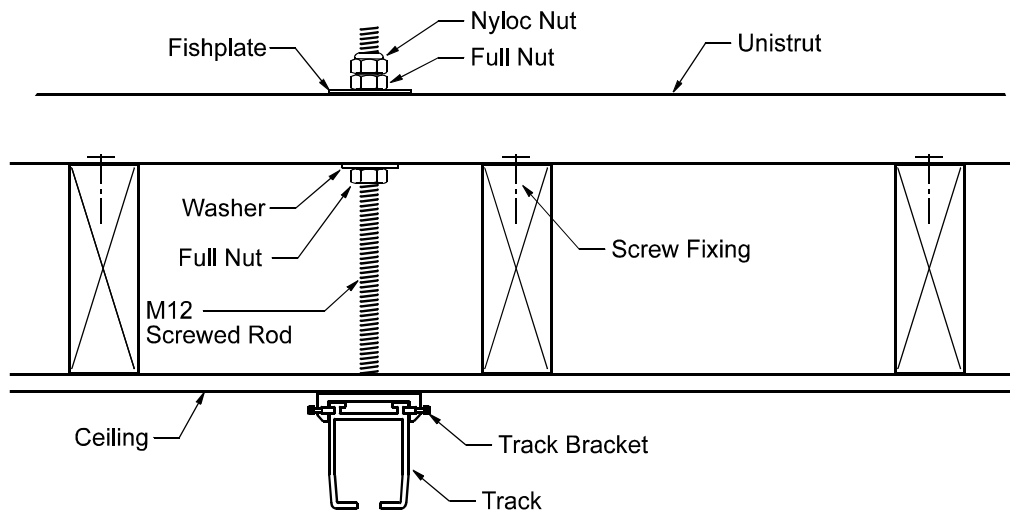

Detail showing the steel channel secured to the joists and the configuration of the M12 screwed rod and locking nuts.

JOIST HANGERS

This type of installation method is used when the hoist tracking is to be installed in a room that has another room above it and access to the floorboards is possible. If the access is not possible due to a tiled floor, glued floors, furniture etc, then the installation can be completed using coachscrews and support plates.

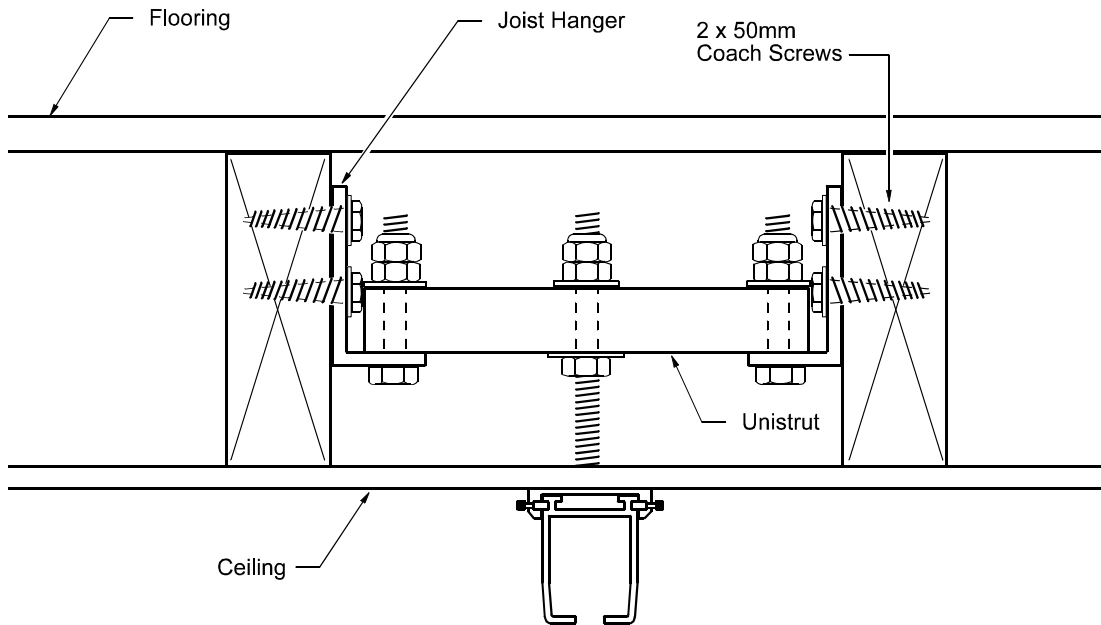

Diagram Showing the Joist Hanger method of fixing with bridged steel channel

If the track is running across the joists, then the bracket spacing is determined by the positions of the joists. Not every joist has to be used. Fixing spacing will be dependant upon the hoist's SWL, track position, length of track and size of joist.

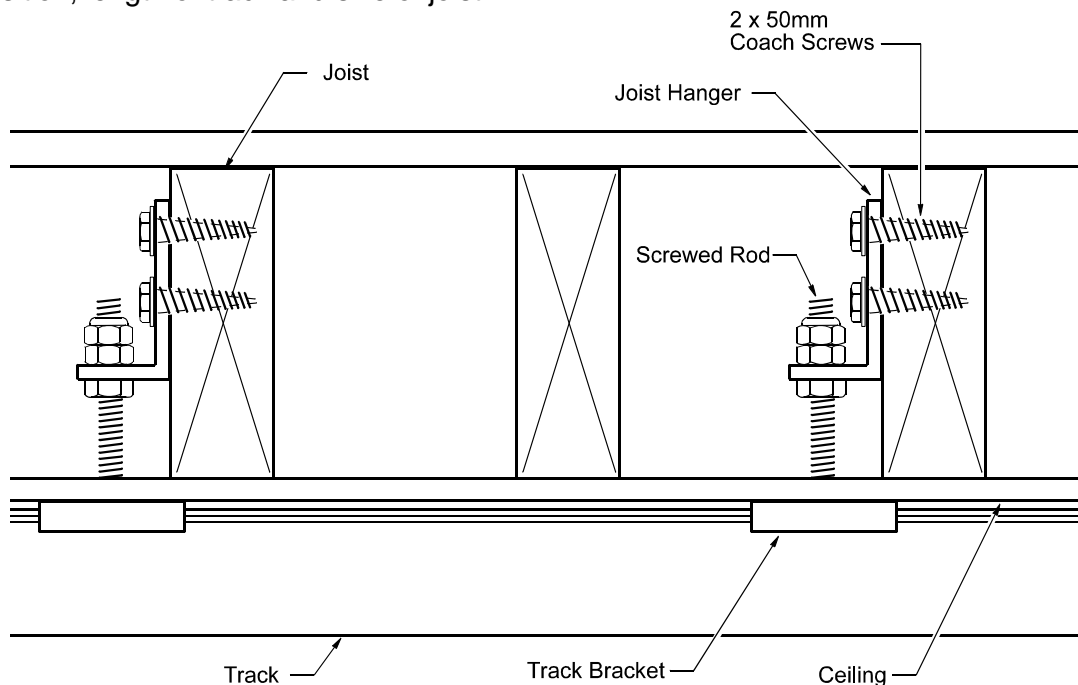
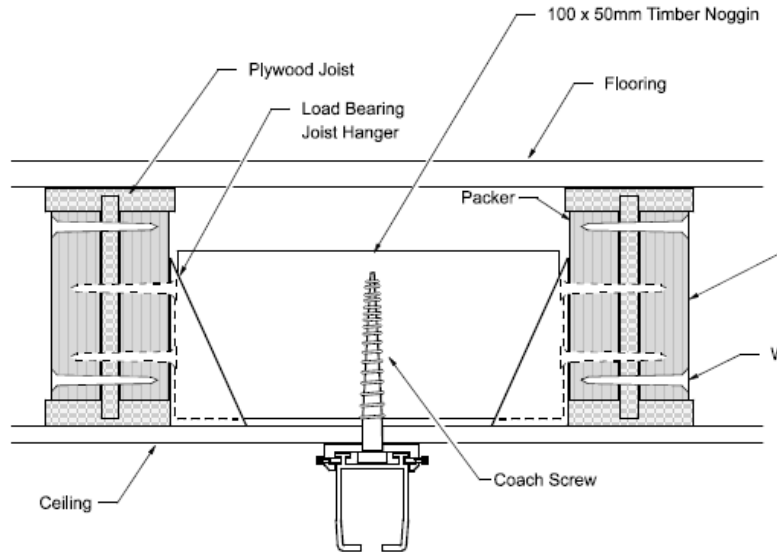

Diagram Showing the Joist Hanger method of fixing

TJI Style Joists

A modern method of construction is to use TJI style joists (examples below) instead of traditional timber joists.

These types of joists are not suitable for coachscrew fixings, and must be packed and supported as below when using the Prism Medical joist hanger method of fixing. If possible, the builder should install timber noggins between the joists to enable direct coachscrew fixing.



150mm X 100mm Timber Noggin on Joist hangers and packing on TJI style joists

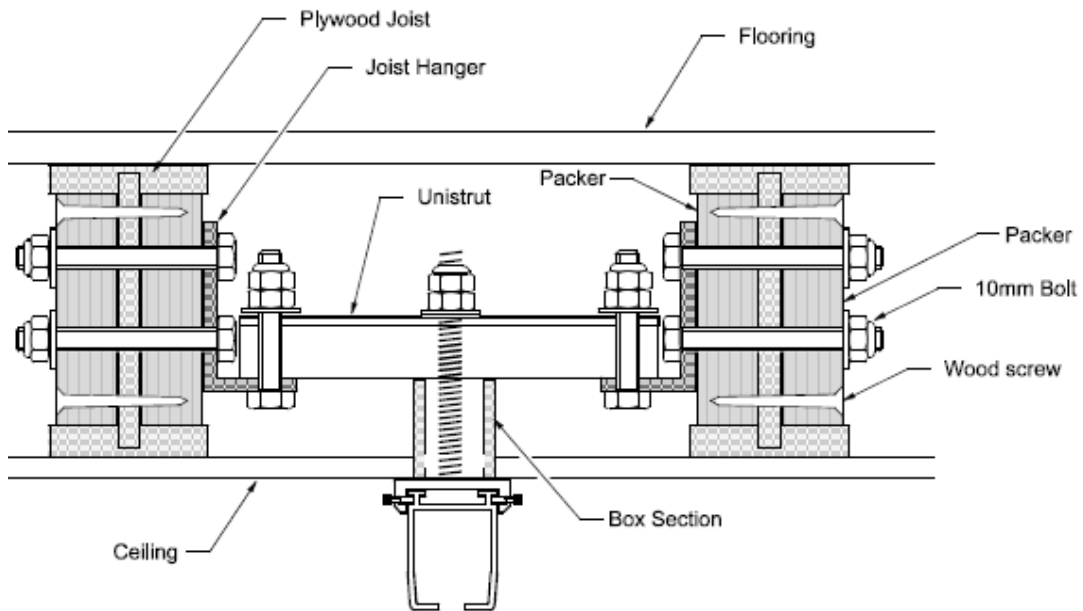

Alternative method when access is available from above

FIXINGS INTO CONCRETE / BEAM & BLOCK CEILINGS

When the ceiling is constructed of pre-cast reinforced concrete, Poured reinforced concrete or of pre-cast concrete sections or beam & block, then the hoist can be installed by using either Fischer Chemical resin or by using Fischer Zykon Fixings.

Full access is needed to block and beam ceilings as the Zykon fixings method of installation requires a circular motion of the drill when preparing the fixing hole.

The surveyor will require the exact construction of the ceiling prior to an installation method being determined.

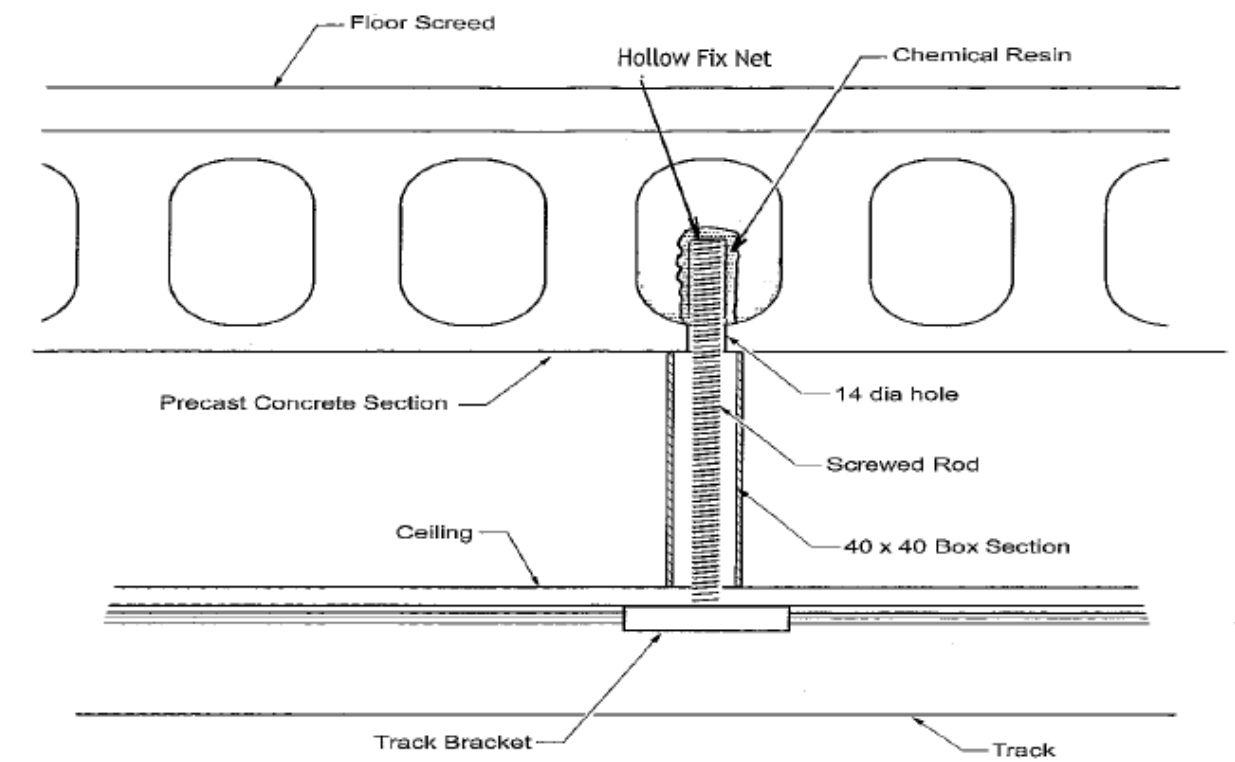

Track suspended from hollow concrete slab using chemical resin

Zykon Fixings

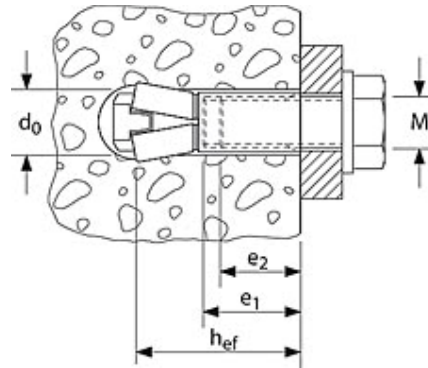

A Fischer Zykon FZEA 2 shown with a bolt fixing

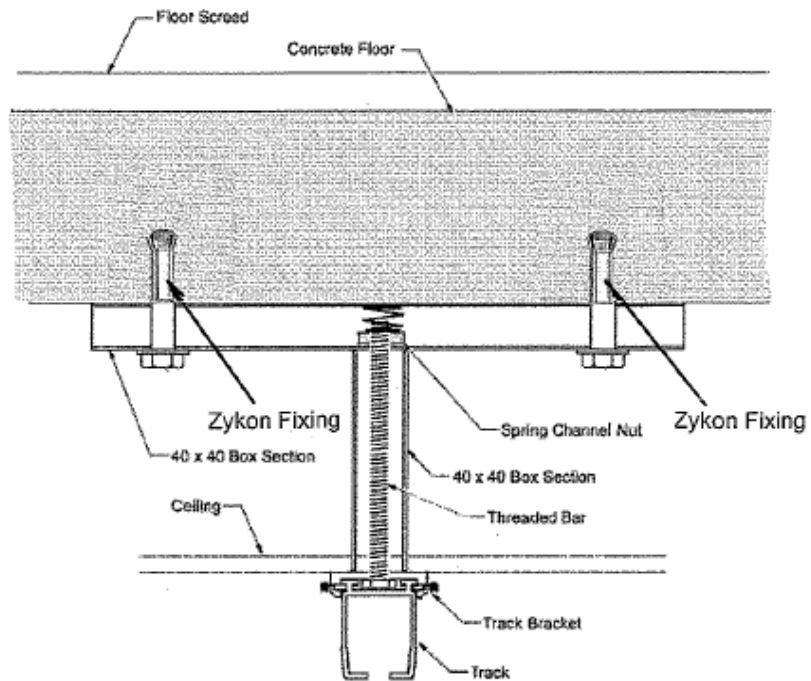

Typical example of a mechanical fixing to concrete with track suspended

WALL TO WALL

Wall to wall fixing is used when it is not possible to hang from the existing ceiling. Spans of up to 2.5 metres can be covered using single track. Spans between 2.5 and 5.0 metres have to be covered using double track.

The track is hung off two wall brackets that have track brackets bolted to them. Special consideration is required when fastening wall brackets to the walls. If the wall is constructed of red brick, then M10 expansion bolts can be used. For all other types of construction i.e thermalite block, concrete blocks etc then a chemical resin such as Fischer FIS-P must be used in conjunction with a minimum threaded bar size of 10mm. When using resin, the manufacturers instructions must be followed at all times.

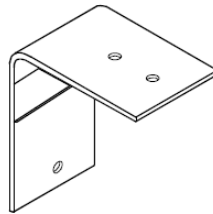
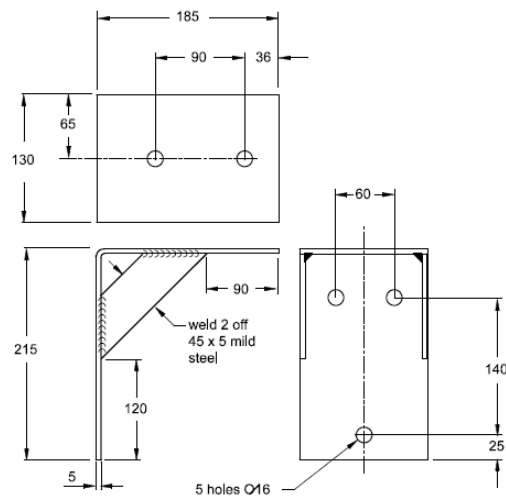

Typical Wall Bracket for Track fixing

Note: Brackets can only be fixed to solid walls.

Wall to Wall - Cont

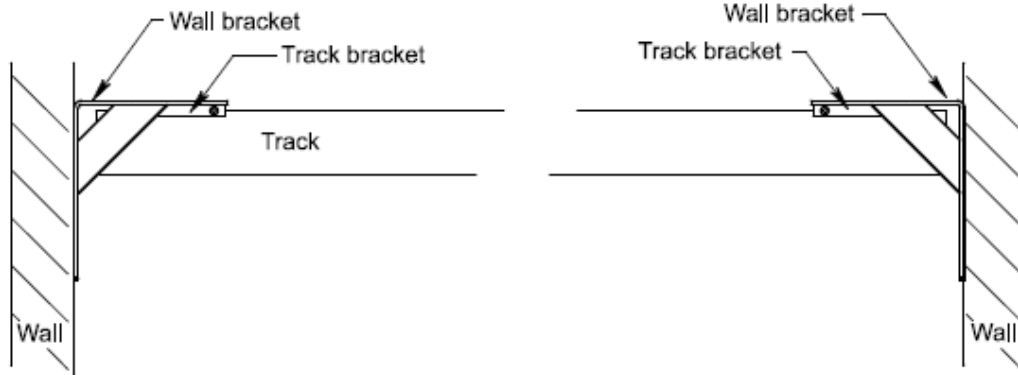

single track installation – Max 2.5m*

* See Chart below

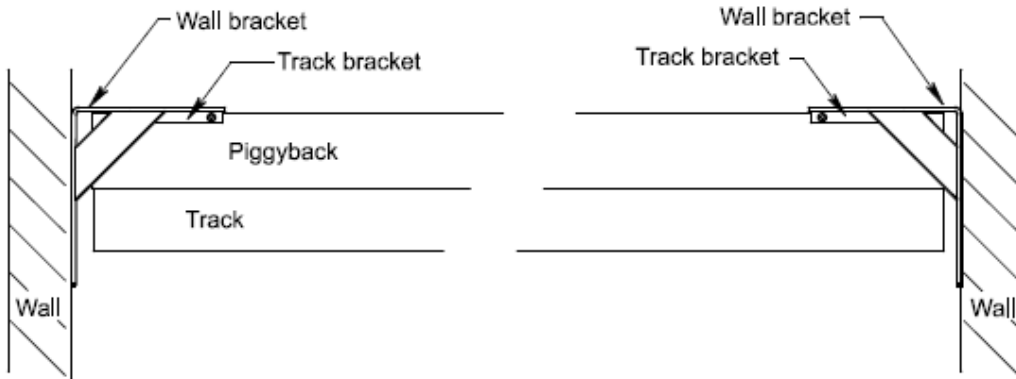

Piggyback (Double Track) installation – Max 5m*

- See Chart below

Chart showing maximum permitted spans for Prism Medical tracking:

<u>Hoist Type</u>	<u>Hoist SWL</u>	<u>Max Span – Single</u>	<u>Max Span - Double</u>
Transactive / Xtra 130	130Kg	2.5m	5m
Transactive / Xtra 160	160Kg	2.5m	5m
Transactive / Xtra 200	200Kg	2.3m	5m
Transactive 300 / TX 270	300Kg	1.9m	4.5m
P-200	200KG	2.3m	5m

STEELWORK & GANTRY LEG SYSTEMS

Prism Medical also has a unique 'side hanging' steel option that can be used instead of double track when lifting height is restricted.

The track runs along side a length of white coated steel and is supported on flat bars protruding from the top of the steel. Steelwork can be installed wall to wall or from additional steelwork gantry legs or a combination of the two.

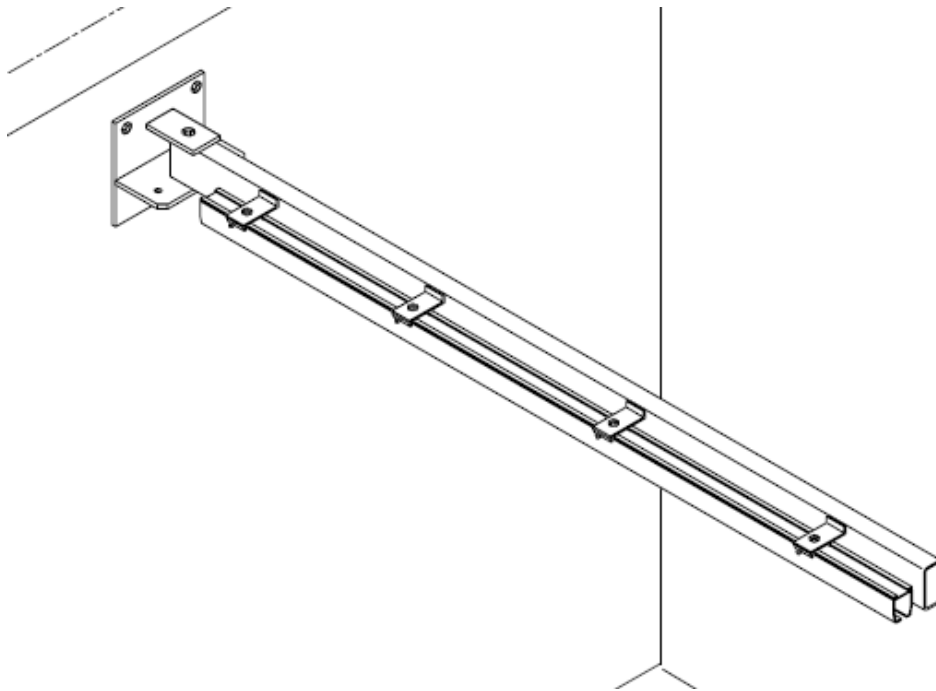

Diagram of Side Hanging Steel and Hoist Track

Gantry Legs

Gantry Leg systems are used in situations where it is not possible to hang the track from the ceiling and the room walls are not built of a material suitable to fasten wall brackets to, e.g. stud partition walls.

Gantry frames are made to suit a specific job and come in all different shapes and sizes. When using gantry legs, it is important to make sure that they are secured to either the wall or floor or both, depending on the circumstances of the installation. Gantry Systems that are required in wet areas such as bathrooms or swimming pool areas are galvanised and powder coated to afford extra protection to the steel.

Combinations of wall brackets and gantry legs can be used for the steelwork. For spans of 2.5m or less, single track can be used fastened direct to the gantry legs or wall brackets.

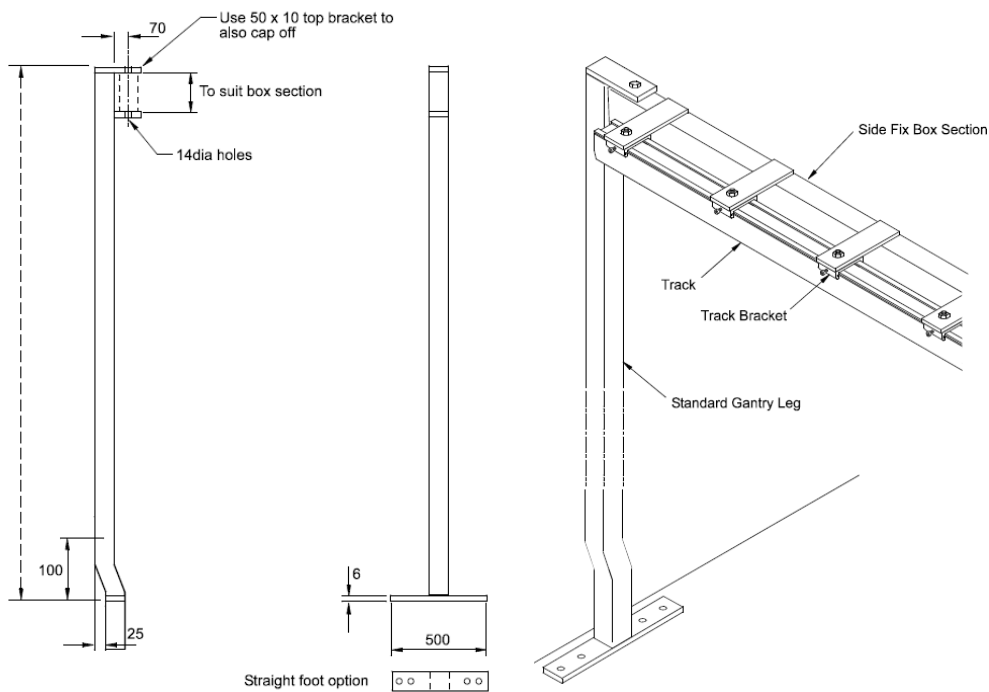

The gantry leg shown is for steelwork fixing – an option with a single top plate is also available for track only fixing.

TURNTABLES

The turntable is ideal for situations where junctions are required in a track or when a track turn is required that the standard curved sections cannot accommodate.

The turntable can be supported in a variety of ways, but must always be supported at 4 points that are evenly distributed to prevent the back-plate from twisting when under load.

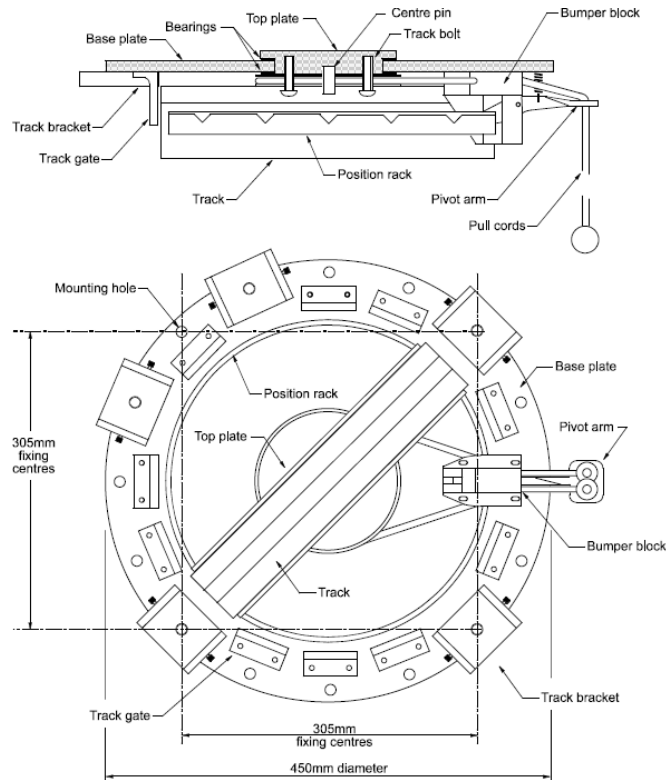

Turntable Dimensions and Fixing Points

Powered Turntable

The Turntable is also available in a powered version with the option of turning to and from 2 preset positions. These positions will be assessed and the turntable manufactured accordingly.

Please note that the power for the turntable is sourced from the hoist and must be ordered with a compatible hoist unit.

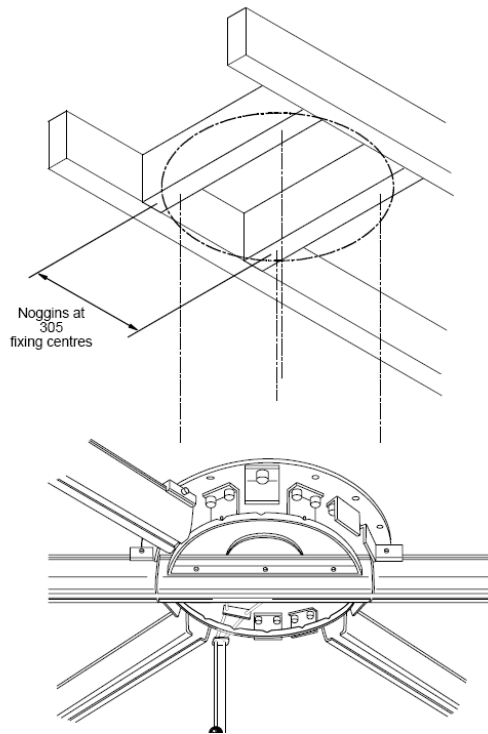

Typical Joist / Noggin position for Turntable Installation

Turntable - Cont

Bends that come directly from a turntable must not be cut back past the straight section otherwise the hoist will not pass from the turntable to the track. A minimum of 100mm of straight track must be left on the bend.

Example of the versatility of using a turntable

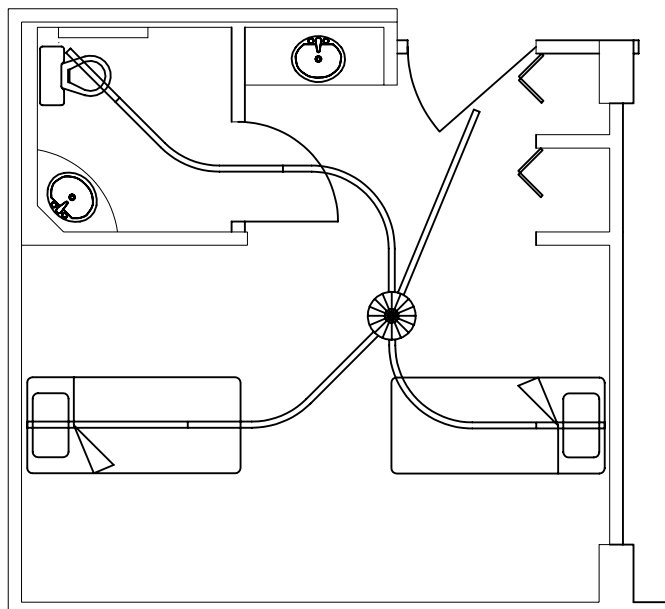

'H' – SYSTEM (Also known by other manufactures as an X-Y System)

The 'H'-System consists of a traversing beam that is suspended below two tracks that are installed parallel to one another (tolerance of +/-3mm). The system can be provided in various options, which are: -

- Manual 'H'- traverse, motorised hoist traverse.
- Manual 'H' – traverse, manual hoist traverse.
- Motorised 'H'-traverse, motorised hoist traverse (Max 3m traversing beam).
- Motorised 'H'-traverse, manual hoist traverse (Max 3m traversing beam).

N.B. All options have motorised lift / lower function

The most important factor when installing an 'H'-System is that the support tracks must be installed parallel to one another.

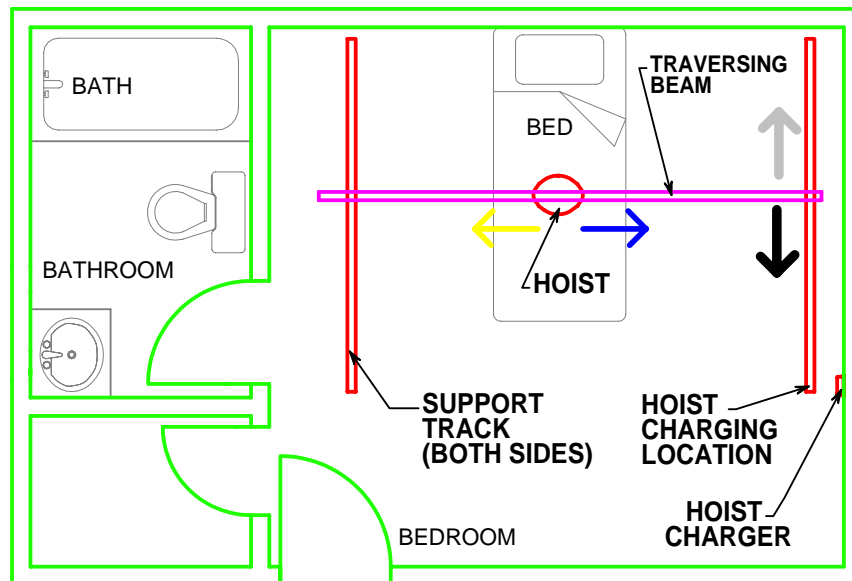

Typical Example of a H-System installation

A popular way of covering both Bedroom & En-suite is to install the H-System between both rooms as per the image below. Wall details and dimensions are available on request.



Typical example of a 2-Room Covering H-System

TRANSITION GATE

The Transition Gate adds the facility to transfer the hoist seamlessly from a 'H'-System onto a fixed piece of track as shown in the diagram below.

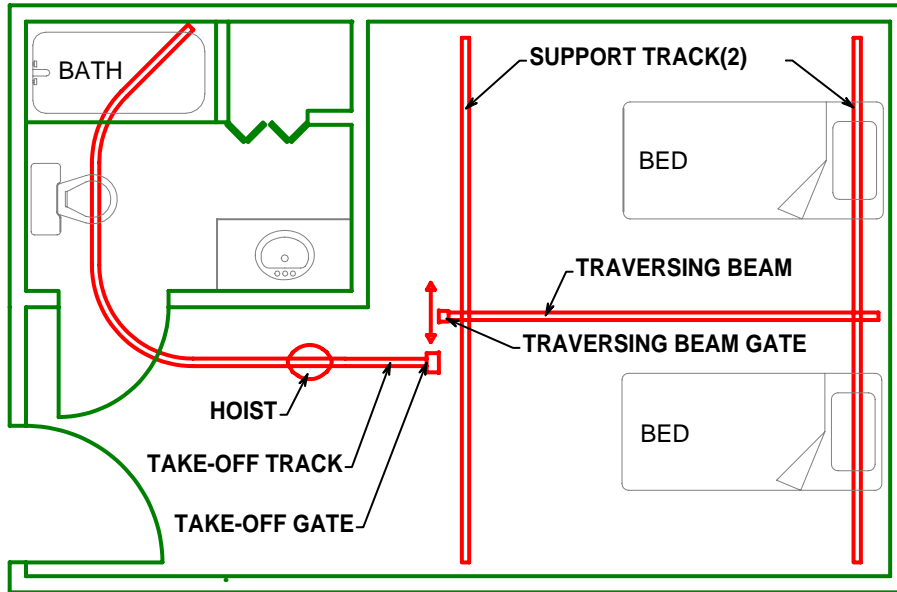

A separate comprehensive installation guide details the requirements for this equipment.



Transition gate locked

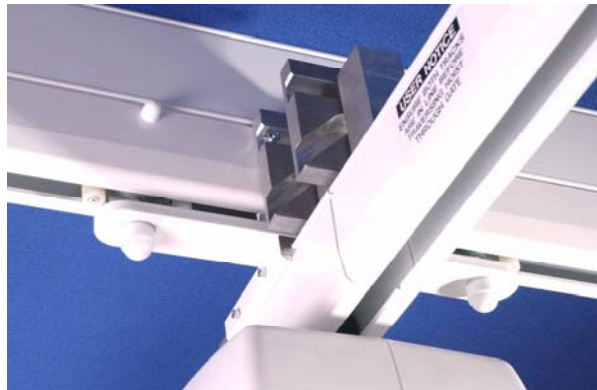

Transition gate open

LOAD TESTING

After the installation is complete, the hoist is proof tested to 125% of the maximum load stated on the label on the hoist. Once loaded with the test weights, the hoist is traversed along the entire track system to qualify the integrity of the installation.

ELECTRICAL CONNECTION

Electrical Requirements

The hoist is battery operated and is charged by parking the hoist at the end of the track where the charger is located.

The Charger is concealed within the track and has an IP rating of IP67. The charger requires the installation of a Switched fused spur (with RCD protection in rooms containing a bath or shower), that is usually placed within 200mm of the end of the track containing the charger. The charger is rated at 15W and has an output of 30v AC. A dedicated supply is not necessary for this type of equipment.

All electrical work must be carried out by a competent electrical engineer in accordance with the current edition of IEE Wiring Regulations.

Critical Dimensions

Pick up point on a bed – 900mm from headboard or 1000mm from the wall if there is not a bed present at the time of installation. The surveyor will specify a measurement if this dimension needs to be altered.

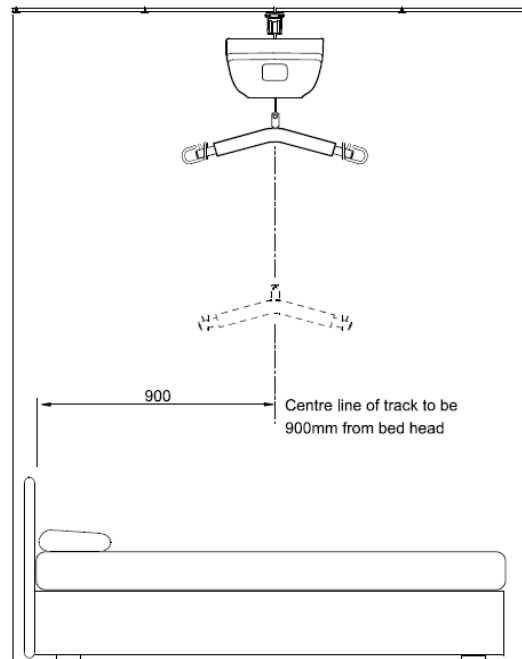

Pick up point from a bath – 250mm from the base of the slope at the rear of the bath.

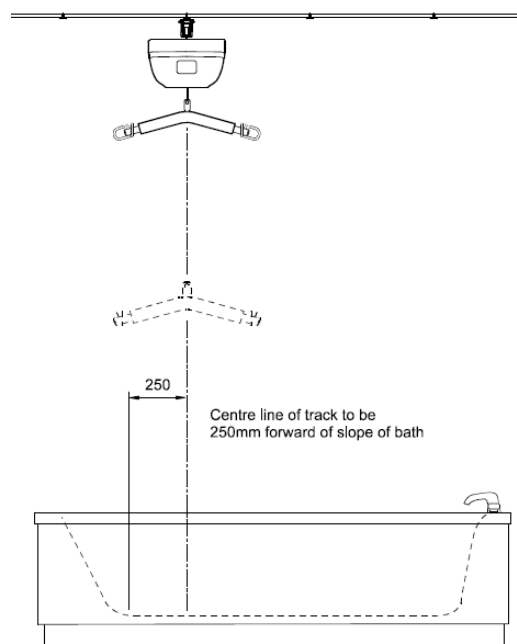

Pick up point on a toilet –50mm forward of the centre of the seat aperture and central front to back.

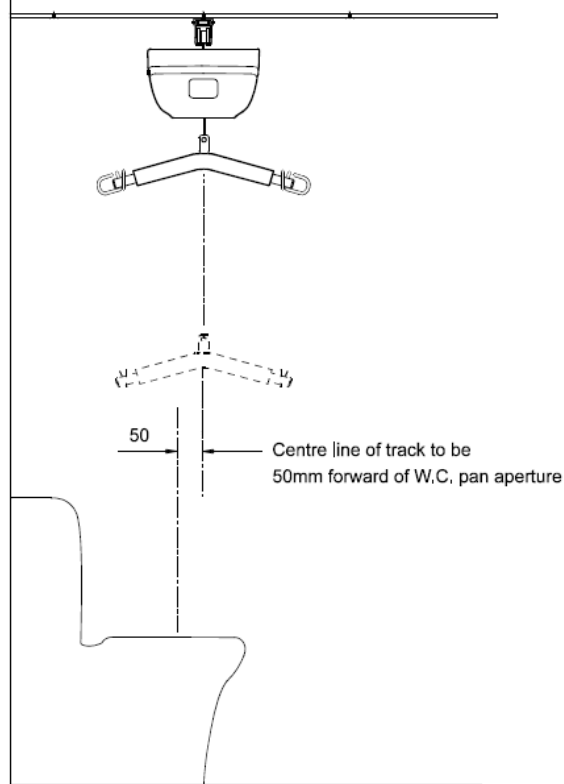

Maximum overhang of track past the last bracket – 250mm

Walls & Obstacles – Minimum distance between any walls, obstacles, door frames etc is 380mm.

The minimum ceiling height is determined by the height of the accessories to be hoisted on or over, and the size and type of sling being used. This will be assessed at the time of survey.

As an approximation, the distance required from the finished ceiling to the persons bottom when using a Prism Medical Medium Universal sling with a hoist installed on single track is approximately 1450mm, dependent upon the persons body shape. This would mean that the ceiling height required to hoist this person onto a changing bench set at 900mm would be $900 + 1450 = 2350\text{mm}$.

To perform lifts from the floor, the maximum ceiling level can be 3300mm. Extended tapes are available for ceilings that are higher than this.

Room to Room System Through a Full Height Door

Door Detail for Single Track room to room – See diagram below

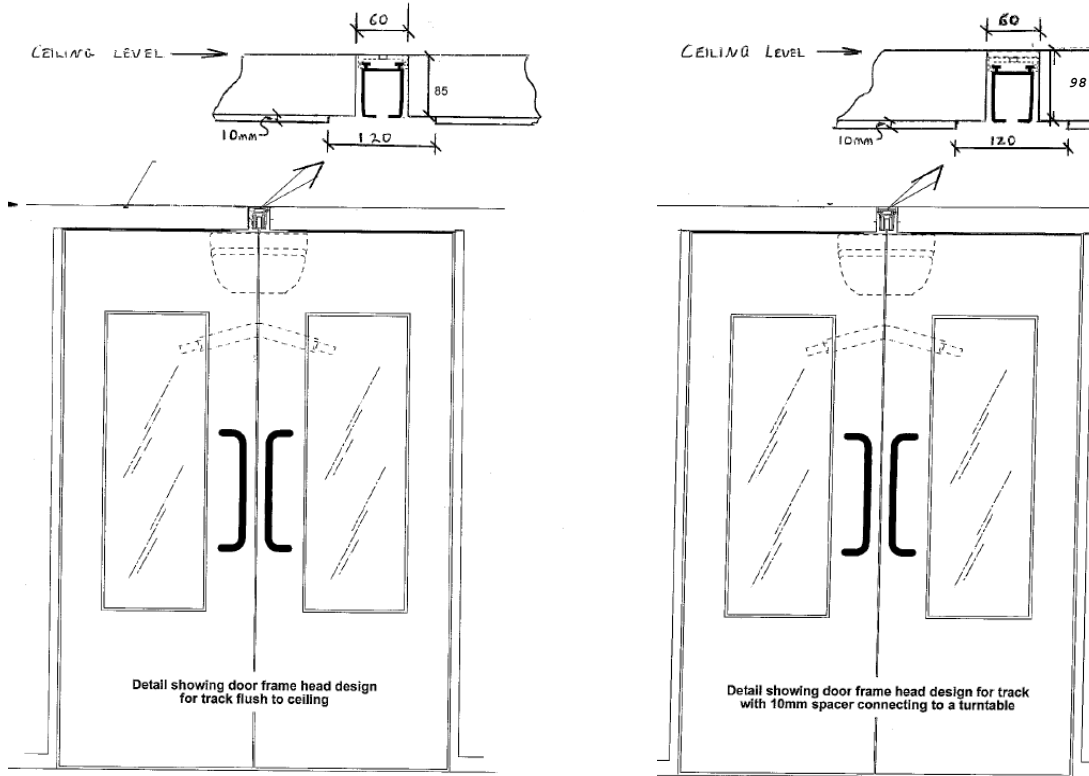

Door Detail for Single Track

Door Detail for single track with Turntable

The frame detail is the same for a single swing door as it is for the double doors in the diagrams above.

NOTES

PRISM MEDICAL UK

HEALTHCARE DIVISION

Unit 4, Crispen Court, Newbiggin Lane, Newcastle Upon Tyne, Tyne & Wear NE5 1BF
T +44 (0)844 980 2278 **F** +44 (0)844 980 2279 **E-mail:**healthcareinfo@prismmedical.co.uk
www.prismmedical.co.uk
© Prism Medical UK 2010